

# Principles of Financial and Managerial Accounting II

## Standard Costs

### *Recording Variances in the Accounts*

#### Introduction

The lecture presentation explained the importance of using standard costs in manufacturing operations. The calculation of variances from standards and reporting these variances to management provides useful information for decision making purposes. Journal entries are needed to accumulate and report actual and standard costs in the accounting system. A presentation is available on the class web site (<http://oruaccounting.com>) which tells “the rest of the story” by illustrating the necessary entries.

#### Things You Will Need

- Since this presentation is a continuation of the exercise used in lecture, you will need the data from the exercise from the note taking guide.
- Having the notes you took in lecture of the calculations of the variances would also be helpful and necessary.
- This handout should help you take notes as you read through the information presented. However, remember the main objective is not to fill in all the blanks, but rather to *understand* the material being presented.

When you see the calculator in the presentation, be sure to take the time to refer to the calculations you made previously and mentally “connect” them to the entries being made.

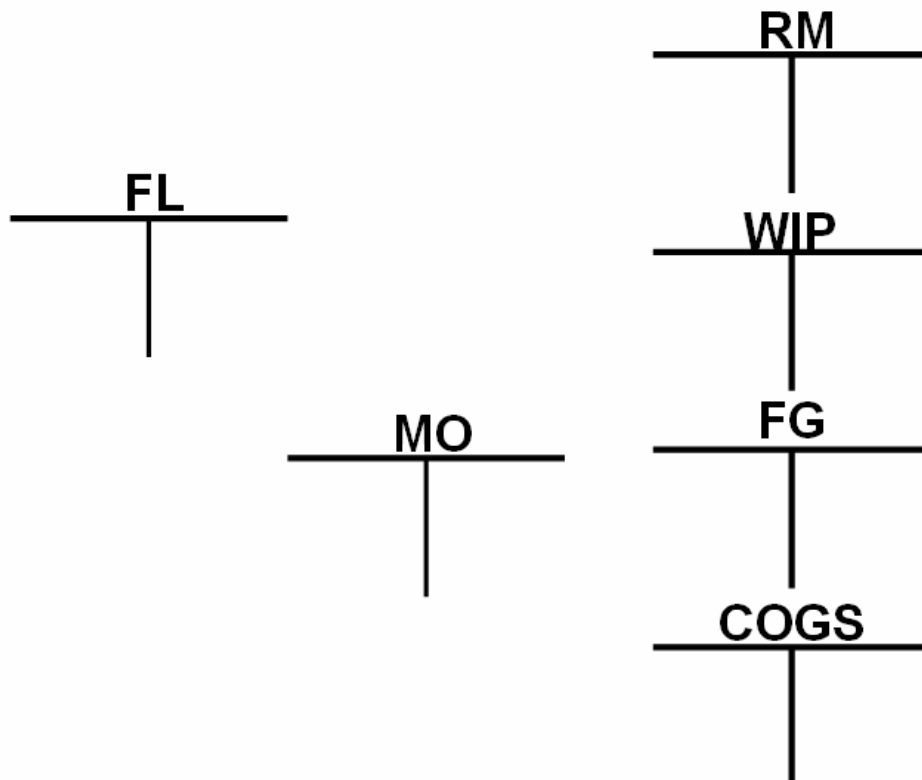

## Materials Price Variance

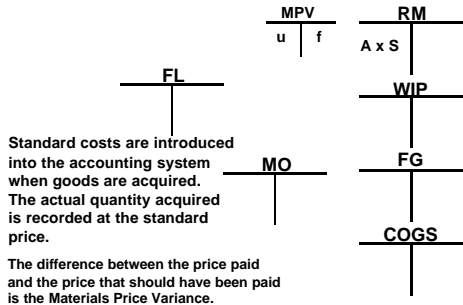

Standard costs are introduced into the accounting system when goods are acquired. The actual quantity acquired is recorded at the standard price.

The difference between the price paid and the price that should have been paid is the Materials Price Variance.

Copyright © 2002 by M. Ray Gregg. All rights reserved.

8

## Materials Quantity Variance

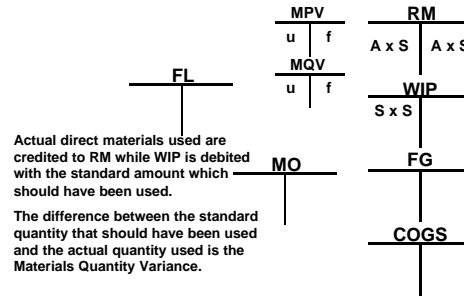

Actual direct materials used are credited to RM while WIP is debited with the standard amount which should have been used.

The difference between the standard quantity that should have been used and the actual quantity used is the Materials Quantity Variance.

Copyright © 2002 by M. Ray Gregg. All rights reserved.

11

## Labor Price Variance

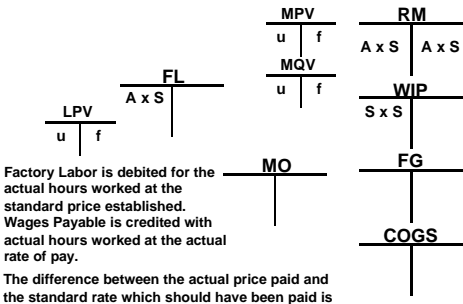

Factory Labor is debited for the actual hours worked at the standard price established. Wages Payable is credited with actual hours worked at the actual rate of pay.

The difference between the actual price paid and the standard rate which should have been paid is the Labor Price Variance.

Copyright © 2002 by M. Ray Gregg. All rights reserved.

14

## Labor Quantity Variance

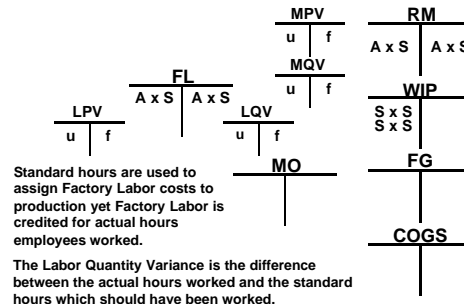

Standard hours are used to assign Factory Labor costs to production yet Factory Labor is credited for actual hours employees worked.

The Labor Quantity Variance is the difference between the actual hours worked and the standard hours which should have been worked.

Copyright © 2002 by M. Ray Gregg. All rights reserved.

17

## Overhead Variances

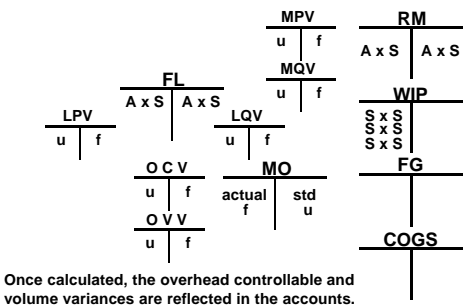

Once calculated, the overhead controllable and volume variances are reflected in the accounts.

Copyright © 2002 by M. Ray Gregg. All rights reserved.

23

## Standards in the Accounts

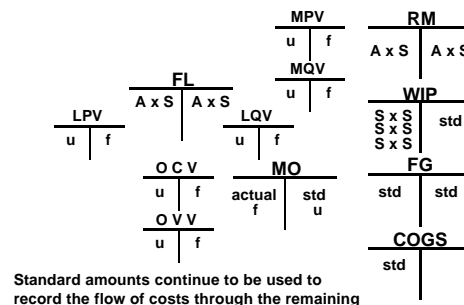

Standard amounts continue to be used to record the flow of costs through the remaining accounts.

Copyright © 2002 by M. Ray Gregg. All rights reserved.

28

## Journal

	<u>Date</u>	<u>Account</u>	<u>P.R.</u>	<u>Debit</u>	<u>Credit</u>
1		Raw Materials			
2					
3		Accounts Payable			
4					
5		Work in Process			
6					
7		Raw Materials			
8					
9		Factory Labor			
10					
11		Wages Payable			
12					
13		Work in Process			
14					
15		Factory Labor			
16					
17		Manufacturing Overhead			
18		Accounts Payable (etc.)			
19					
20		Work in Process			
21		Manufacturing Overhead			
22					
23					
24					
25		Manufacturing Overhead			
26					
27		Finished Goods			
28		Work in Process			
29					
30		Accounts Receivable		retail	
31		Sales			retail
32					
33		Cost of Goods Sold			
34		Finished Goods			

